

Flanged Inline System

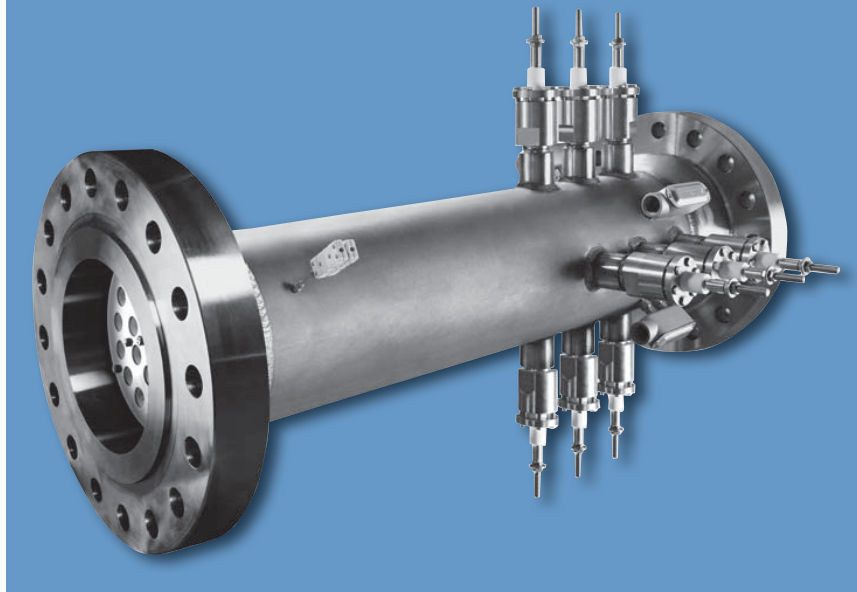

Specifications

- Electric process inline air heater with ANSI standard pipe and flanges for heating high-pressure air or inert gases to 1400°F (760°C) and higher
- With the SYLVANIA patented Serpentine elements, you can reach set point temperature within just a few seconds or minutes, versus the much slower response of tubular element designs
- Standard heater models range from 2.5" pipe size (18kW) to 10" pipe size (400kW). (400kW model shown in photo.) Custom heater models are available upon request
- Maximum static pressures to 150 psi (10 bar)
- Maximum inlet temperature 900°F (482°C)
- Type K thermocouple probes included for accurate control and safety
- Each 6" diameter and larger heater model is supplied with four (4) internal Type K thermocouples attached to heater element for additional protection
- Elements are easily replaceable as a complete cartridge assembly
- Ultra High Pressure (UHP) models (>150 psi) are available with ASME Section VIII Div. 1 code stamp. Models up to 800 psi (54 bar) have been supplied
- Custom SCR power and temperature control cabinets are available on request
- On-site start-up assistance can also be provided
- RoHS compliant



Installation

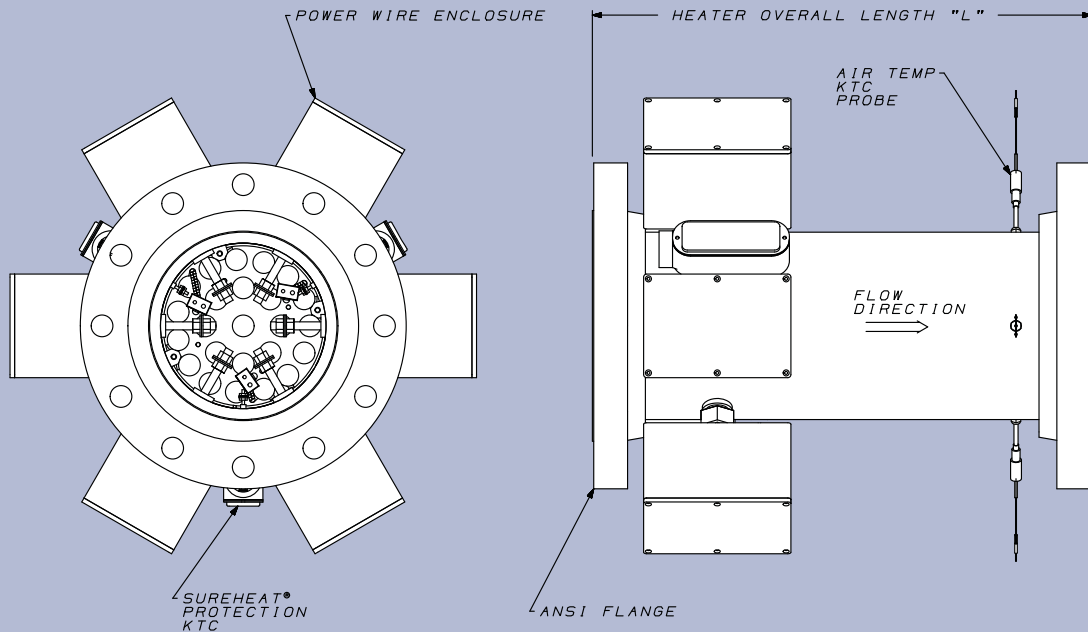

Products

Part Number	Nominal Pipe Size	Max. Watts	Max. Volts	Max. Amps	Overall Length "L"	Flange ANSI Class	Vessel Material	Air Temperature KTC Probes	SUREHEAT Protection KTC's	Replacement Element Part Number
072631	2.5"	18kW	480 - 3 ϕ	22	16.0" (406mm)	150lb	304SS	2	0	076062
076202	2.5"	24kW	480 - 3 ϕ	29	16.0" (406mm)	150lb	304SS	2	0	076203
076208	4"	36kW	480 - 3 ϕ	44	23.0" (584mm)	150lb	304SS	2	0	076209
076204	4"	48kW	480 - 3 ϕ	58	23.0" (584mm)	150lb	304SS	2	0	076205
073377	6"	72kW	480 - 3 ϕ	87	23.0" (584mm)	300lb	304SS	3	4***	073378
076206	6"	96kW	480 - 3 ϕ	116	23.0" (584mm)	300lb	304SS	3	4***	076207
073384	8"	144kW	480 - 3 ϕ	175	23.0" (584mm)	300lb	304SS	3	4***	073385
073153	8"	192kW	480 - 3 ϕ	235	23.0" (584mm)	300lb	304SS	3	4***	073253
076013*	10"	400kW	480 - 3 ϕ	482	52.75" (1340mm)	300lb	316HSS	2**	4***	076041

* Heater P/N F076013 is designed for 300 psi operation.

** Two duplex probes supplied for total of 4 air temperature KTC's.

*** Requires SUREHEAT four-zone limit circuit, SYLVANIA P/N F073262 (purchased separately).