

# DRAGONpuck®

## LED Modules for Accent Lighting Applications



The DRAGONpuck LED module by SYLVANIA bridges the gap between the requirements of white light illumination and the capabilities of LED technology. These modules provide bright and intense illumination for accent lighting applications.

The DRAGONpuck module consists of three hi-flux LEDs mounted on a metal substrate circuit board and an optical lens. The module is more efficient than incandescent or halogen light sources with a similar luminous intensity. DRAGONpuck is optimally paired with SYLVANIA OPTOTRONIC® constant current power supplies.

### Key Features & Benefits

- Compact hi-flux LED light source with an on-board optic for accent lighting applications
- Small, innovative light source design for compact fixtures
- Simple assembly to metallic heat sink surface with an M3x8 screw
- Luminous intensity up to 900 candelas for white light
- No ultraviolet or infrared radiation
- Dimensions (Height x Diameter) 0.48in x 1.38in
- Pre-wired with a 7.9 inch polarized cable
- Optimal operation with OPTOTRONIC constant current power supplies
- Service life of up to 50,000 hours when temperature at Tc point is maintained at 40°C
- Higher efficacy than incandescent or halogen light sources
- Heat sink is available that has been specifically designed for the DRAGONpuck module

### Product Offering

Ordering Description	Wattage (W)	Color
DRAGONpuck/OS/DP3/W3F-727	3.6	2700K
DRAGONpuck/OS/DP3/W3F-854	3.6	5400K

### Application Information

#### Applications

- Task lighting – reading lights, under cabinet lighting
- Accent lighting – cove lighting, outdoor/landscape lighting
- Street lighting
- Refrigeration and freezer display case lighting
- Vehicle cabin lighting – RV, truck, boat, airplane
- Solar powered installations

#### Specifications and Certifications



The SYLVANIA DRAGONpuck is UL2108 Recognized for US and Canada Class 2 Unit (UL file # E258264)

RoHS Compliant

Listed in Sign Components Manual (SAM)



## Specification Data

Catalog #	Type
Project	
Comments	
Prepared by	Date

## Ordering Information

Item Number	Ordering Description	Module Diameter (in.)	No. of LEDs	Power (W)	Voltage (Vdc)	Current per module (A)	Color** (wavelength)	Typical Luminous* Intensity (cd)	Beam Angle (degrees)
70281	DRAGONpuck/OS/DP3/W3F-727	1.38	3	3.6	10.3	0.35	2700K	630	16
70169	DRAGONpuck/OS/DP3/W3F-854	1.38	3	3.6	10.3	0.35	5400K	900	16

\* All data is related to entire module. Due to the special conditions of the manufacturing processes of LEDs, the typical data of technical parameters can only reflect statistical figures and do not necessarily correspond to the actual parameters of each single product which could differ from the typical data.

\*\*CRI >70 for all 2700K. All other white color temperatures have a CRI >80.

## Ordering Guide

DRAGONpuck	/	W3F	-	7-8	27
Module Name		White 3rd Generation Fine Binning		CRI 7 > 70 8 > 80	Color Temperature 27 = 2700K 54 = 5400K

## Power Supply Information

LED Item Number	Color	OT3/120-240/350 (51524)	OT9/100-120/350 E or OT9/10-24/350 DIM E (51525 or 51526)	OT10/120-240/350 E (51635)	OT25/120-277/700 E (51527)
		No. of Modules	No. of Modules	No. of Modules	No. of Modules
70281	727 (W3F)	1	2	2	6
70169	854 (W3F)	1	2	2	6

NoteS:

- The module is designed to work with Constant Current power supplies only. Use of Constant Voltage power supplies and reverse operation is not allowed and may destroy the module.
- SYLVANIA OPTOTRONIC power supplies are specifically designed with protection features for safe operation.

## Minimum and Maximum Ratings

Parameter	Symbol	Values
Operating Temperature at Tc point	$T_{op}$	-30... +85°C (-22 to +185°F)
Storage Temperature	$T_{stg}$	-30... +85°C (-22 to +185°F)
Maximum Allowable Current (dc)	$I_{max}$	350mA
Maximum Reverse Voltage	$V_R$	0 Vdc

Notes:

- Exceeding maximum ratings for operating and storage temperature will reduce expected lifetime or destroy the LED Module.
- Exceeding maximum ratings for operating current will cause hazardous overload and will likely destroy the LED Module.
- The temperature of the LED Module must be measured at the Tc point in a thermally constant status with a temperature sensor or a temperature sensitive label.  
For exact location of the Tc point see the "Assembly Drawing".

## Accessories



Item Number	Ordering Abbreviation	Description	Diameter	Height
70136	Heatsink/DRAGONpuck-50	Heatsink	3.5 in.	0.79 in.

## Assembly Diagram

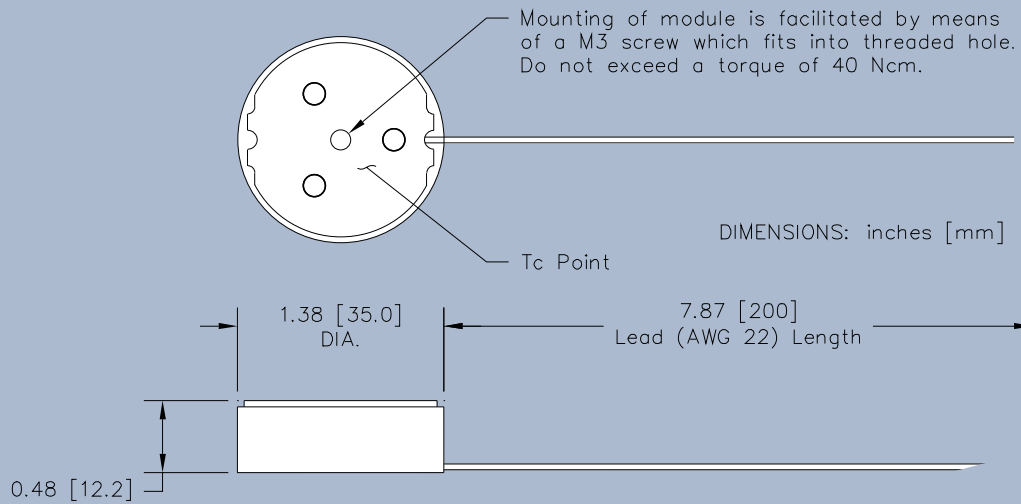

## Wiring Diagram

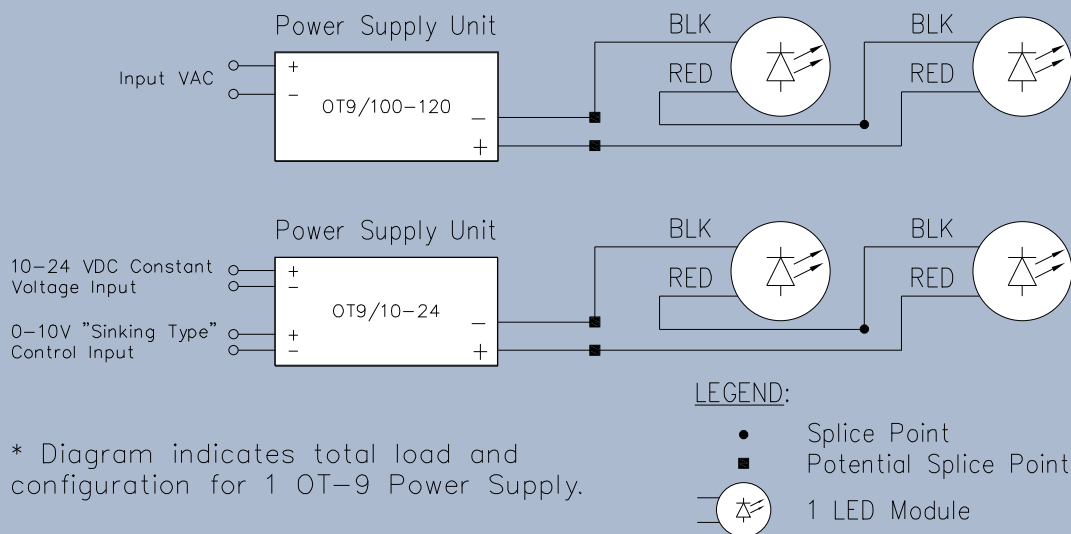

## Safety Information

**WARNING: ONLY QUALIFIED PERSONNEL SHOULD PERFORM INSTALLATION.  
TO AVOID ELECTRICAL SHOCK OR COMPONENT DAMAGE, DISCONNECT POWER  
BEFORE ATTEMPTING INSTALLATION OF THE POWER SUPPLIES AND/OR MODULES.**

Failure to install the power supplies and/or LED modules in accordance with the National Electric Code (NEC), all applicable Federal, State and local electric codes as well as the specific Underwriter's Laboratories (UL) safety standards for the installation, location and application may cause serious personal injury, death, property damage and/or product malfunction.

1. The LED module itself and all its components shall not be subjected to mechanical stress and assembly must not damage or destroy conducting paths on the circuit board.
2. Observe correct electrical polarity (depending on the product, incorrect polarity may lead to emission of red, or no light); incorrect polarity may destroy the module.
3. Ensure that the power supply is of adequate power to operate the total load.
4. Electrostatic Discharge (ESD) precautions shall be incorporated when handling or installing the module.
5. Damage by corrosion and improper heat sinking will not be honored as a material defect claim. It is the user's responsibility to ensure adequate heat sink and protection against corrosive agents such as moisture, condensation, or other harmful elements.
6. Modules may be hot to the touch. Use caution when handling.

## Assembly Information

1. The module should be in good thermal contact with the designed metallic mounting surface. Use of an appropriate heat sink compound is recommended to eliminate air gaps.
2. To obtain maximum LED-lifetime please read carefully the recommended procedures concerning thermal management in our application note "Lifetime of LED-modules" before beginning construction of luminaires. This application note is available from your SYLVANIA representative.
3. Installation of the DRAGONpuck must include provision for thermal management to avoid premature failure of the product and to obtain expected service life. Service life (i.e. lumen depreciation) is primarily a function of LED temperature which is to be monitored on the circuit board at the designated "Tc point".
4. There is no exact installation prescription to obtaining an appropriate Tc point temperature because every fixture design is different. In general, the DRAGONpuck module should be mounted to a clean, flat metal surface which has enough surface area to transfer the heat from the module to the surrounding air. The metal surface can be part of a conventional finned heat sink or can be part of the mass of the fixture itself.
5. Concerning fixture design, it is important to understand that once heat is transferred to a "heat sink", that heat must still be allowed to escape the "system". A heat sink transferring the thermal energy to the inside of an enclosed cavity may ultimately be of little use.
6. The fixture makers' strategy should be to design a prototype fixture and test that fixture in an appropriate ambient environment while monitoring the temperature at the Tc point which should be allowed enough time to reach thermal equilibrium. Tc point temperature can be measured with a standard thermocouple in direct contact with the circuit board at the Tc point or by use of ML4C Series non-reversible OMEGALABELS ([www.omega.com](http://www.omega.com)) or equivalent.

OPTOTRONIC and DRAGONpuck are registered trademarks of OSRAM GmbH.  
SYLVANIA is a registered trademark of OSRAM SYLVANIA Inc.  
SEE THE WORLD IN A NEW LIGHT is a registered trademark of OSRAM SYLVANIA Inc.  
Specifications subject to change without notice.

**United States  
OSRAM SYLVANIA**  
100 Endicott Street  
Danvers, MA 01923

**Trade**  
Phone: 1-800-255-5042  
Fax: 1-800-255-5043

**National Accounts**  
Phone: 1-800-562-4671  
Fax: 1-800-562-4674

**OEM/Special Markets**  
Phone: 1-800-762-7191  
Fax: 1-800-762-7192

**Display/Optic**  
Phone: 1-888-677-2627  
Fax: 1-800-762-7192

**Canada  
OSRAM SYLVANIA LTD.**  
2001 Drew Road  
Mississauga, ON L5S 1S4

**Trade**  
Phone: 1-800-263-2852  
Fax: 1-800-667-6772

**OEM/Special Markets/Display/Optic**  
Phone: 1-800-265-2852  
Fax: 1-800-667-6772

[www.sylvania.com](http://www.sylvania.com)