

# CAPSYLITE IR® PAR LAMPS

## Halogen Lamps



The SYLVANIA family of CAPSYLITE IR PAR lamps offers substantial energy savings, great color, long life and state-of-the-art optics.

The exclusive, single-end infrared conserving halogen capsule is at the heart of all SYLVANIA CAPSYLITE IR lamps. This special infrared conserving coating reflects radiated heat back onto the tungsten coil. Recycling this invisible infrared energy lowers the wattage of the capsule and produces more visible light. This increase in lamp efficiency makes it possible to increase the lamp life, increase the light output and decrease the energy used.

SYLVANIA CAPSYLITE IR PAR lamps are the best choice when consistent, crisp, bright light, long life and energy efficiency are required.

### Key Features & Benefits

- High output halogen capsule with an IR-conserving coating for maximum energy efficiency
- Patented SPL® optics to deliver the optimum optical performance
- 3000 to 4000 hour life
- IR conserving capsule produces more light with fewer watts than conventional halogen lamps, reducing energy consumption
- Crisp, bright halogen light
- Consistent lamp-to-lamp optical performance
- IR conserving coating further reduces the already low level of UV present in standard halogen PAR lamps
- Available in PAR20, PAR30, PAR30LN and PAR38
- CAPSYLITE IR PLUS available; its unique enhanced coating increases color temperature while minimizing lumen loss

ECOLOGIC® is a comprehensive program of OSRAM SYLVANIA focused on addressing environmental issues at all stages of lamp life.



### Product Offering

Product	Beam Angle
40W PAR20	SP 10°, FL 30°, WFL 40°
40W PAR30	NSP 9°, NFL 25°, FL 40°
50W PAR30	NSP 9°, NFL 25°, FL 40°
40W PAR30LN	SP10°, NFL25°, WFL50°
50W PAR38	NSP 9°, NFL 25°
60W PAR38	NSP 9°, WSP 12°, NFL 25°, FL 30°
60W PAR38 CAPIR+	VNSP7

#### Applications

- Highlight merchandise
- Accent / display lighting
- Floor lighting
- General lighting
- Indoor / outdoor
- Retail
- Art galleries
- Hotels
- Restaurants
- Offices
- Homes

#### Application Notes

1. Lens stamped with beam pattern
2. Better cutoff – maximum lumens in the beam
3. Eliminates stray light at the edges of the beam pattern
4. Superior candlepower rating
5. Distinctive appearance and superior performance due to SPL optics



## Specification Data

Catalog #	Type
Project	
Comments	
Prepared by	Date

## Ordering Information

Item Number	Ordering Abbreviation	Watts	Base	Average Rated Life (hrs.)	Volts	CBCP	Beam Angle	Lumens	MOL
14164	40PAR20/CAPIR/SP10	40	E26 Medium	4000	120	4200	10°	510	3.250"
14166	40PAR20/CAPIR/NFL30	40	E26 Medium	4000	120	1100	30°	510	3.250"
14130	40PAR20/CAPIR/WFL40	40	E26 Medium	4000	120	800	40°	510	3.250"
13968	40PAR30/CAPIR/SP9	40	E26 Medium	4000	120	8100	9°	610	3.625"
13969	40PAR30/CAPIR/NFL25	40	E26 Medium	4000	120	2100	25°	610	3.625"
13970	40PAR30/CAPIR/FL40	40	E26 Medium	4000	120	1200	40°	610	3.625"
14355	50PAR30/CAPIR/SP9	50	E26 Medium	3000	120	13,000	9°	900	3.625"
14354	50PAR30/CAPIR/NFL25	50	E26 Medium	3000	120	2900	25°	900	3.625"
14132	50PAR30/CAPIR/NFL25	50	E26 Medium	3000	130	2900	25°	900	3.625"
14714	50PAR30/CAPIR/FL40	50	E26 Medium	3000	120	1400	40°	900	3.625"
14131	50PAR30/CAPIR/FL40	50	E26 Medium	3000	130	1400	40°	900	3.625"
15299	40PAR30LN/CAPIR/SP10	40	E26 Medium	4000	120	8100	10	610	4.625"
15301	40PAR30LN/CAPIR/NFL25	40	E26 Medium	4000	120	2100	25	610	4.625"
15302	40PAR30LN/CAPIR/WFL50	40	E26 Medium	4000	120	650	50	610	4.625"
14136	50PAR38/CAPIR/SP9	50	E26 Medium Skirt	3000	120	15,000	9°	850	5.313"
14124	50PAR38/CAPIR/SP9	50	E26 Medium Skirt	3000	130	15,000	9°	850	5.313"
14138	50PAR38/CAPIR/NFL25	50	E26 Medium Skirt	3000	120	3000	25°	850	5.313"
14125	50PAR38/CAPIR/NFL25	50	E26 Medium Skirt	3000	130	3000	25°	850	5.313"
14288	60PAR38/CAPIR/PLUS/VNSP7	60	E26 Medium Skirt	3000	120	22,000	7°	970	5.313"
14485	60PAR38/CAPIR/SP9	60	E26 Medium Skirt	3000	120	19,000	9°	1110	5.313"
14716	60PAR38/CAPIR/SP9	60	E26 Medium Skirt	3000	130	19,000	9°	1110	5.313"
14360	60PAR38/CAPIR/WSP12	60	E26 Medium Skirt	3000	120	12,000	12°	1110	5.313"
14442	60PAR38/CAPIR/NFL25	60	E26 Medium Skirt	3000	120	4000	25°	1110	5.313"
14466	60PAR38/CAPIR/FL30	60	E26 Medium Skirt	3000	120	3000	30°	1110	5.313"
14715	60PAR38/CAPIR/FL30	60	E26 Medium Skirt	3000	130	3000	30°	1110	5.313"

## Ordering Guide

60	PAR	38	LN	/	CAP	/	IR	/	SP	10
Wattage: 40, 50, 60	Parabolic Reflector	Diameter 20 = 2-1/2" 30 = 3-3/4" 38 = 4-3/4"	Long Neck		CAPSYLITE		Infrared Conserving Technology		Beam Spread: VNSP = Very Narrow Spot SP = Spot WSP = Wide Spot NFL = Narrow Flood FL = Flood	Beam Angle 7°, 9°, 10°, 12°, 25°, 30°, 40°, 50°

### IR Coated Capsule

While producing visible light, all Incandescent and Halogen filaments also produce a significant amount of heat. Unfortunately, the heat energy produced by the filament is wasted which also increases the load on HVAC systems. CAPSYLITE IR® lamps have a multi-layered thin film coating on the outer surface of the capsule. This coating allows visible light to pass through it while reflecting infrared heat back to the filament. The reflected energy helps to maintain the coil at its optimum operating temperature and lowers its power consumption. The result is more visible light generated for each watt that is consumed. CAPSYLITE IR lamps can be used to replace higher wattage PAR lamps to achieve similar lighting effects with lower energy costs and less heat generation.

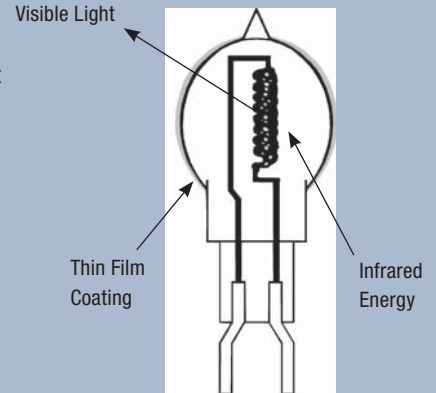

### Optical Performance



Standard Halogen PAR

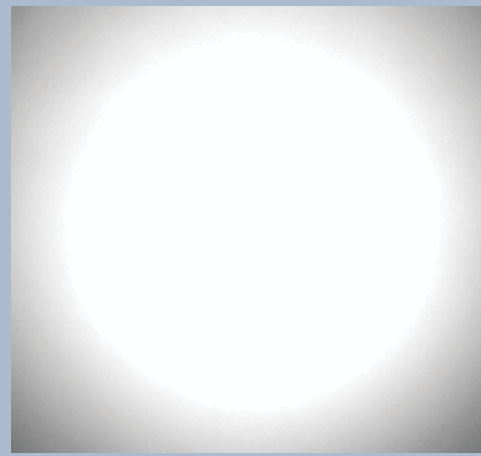

CAPSYLITE IR

### CAPSYLITE® SPL® Optical System

CAPSYLITE IR® lamps employ a patented spiral lenticule layout on their lenses. These patterns were computer designed to deliver a smooth, round beam pattern that is free from hot spots and stray light. The lenses, however, are only half of the story. The spiral flat reflectors were also computer designed to work in concert with the lenses. The spiral flats on the inner surface of the reflector begin to shape and contour the light rays before they reach the lens. The reflector and the lens, therefore, share the job of controlling the light so that the resultant beam pattern is as smooth as possible. The optical system maximizes the lumens in the beam angle, while providing consistent lamp-to-lamp performance.

Energy Cost Savings by Wattage Savings\*

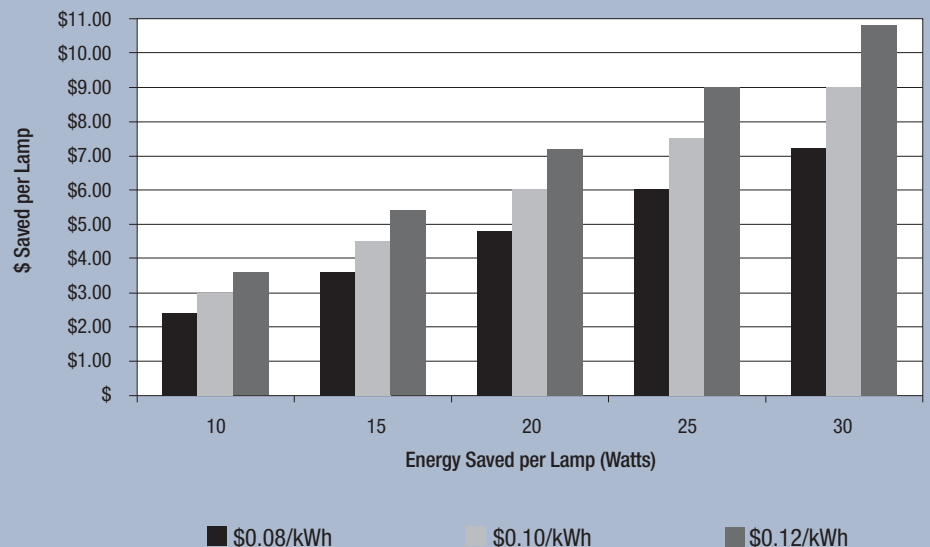

## Technical Information (continued)

### Dimensions

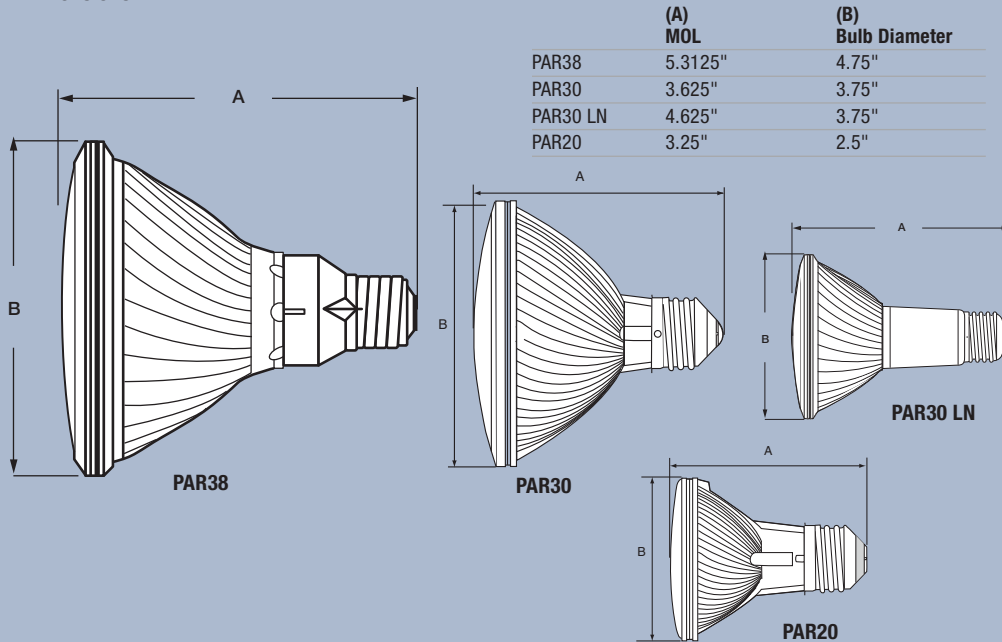

Lamp(s) shall be (a) CAPSYLITE IR halogen PAR (20, 30, 38) lamp(s) with a (3000, 4000) hour average rated life.

Lamp(s) shall be energy efficient and produced to EPACT standards. Lamp base shall contain no lead solder to make the disposal of used CAPSYLITE IR lamp(s) easier for the end user.

### Beam Performance

#### Comparison of Standard Halogen PAR to CAPSYLITE IR® with SPL® Optics

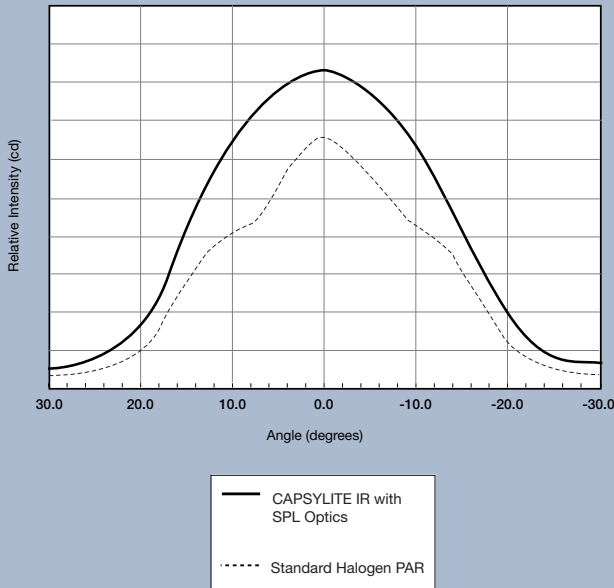

The beam performance of the CAPSYLITE product line with SPL optics changes the way PAR lamps are specified. Traditionally, PAR lamps were designed to provide peak intensity in the center of the beam and the light level dropped rapidly from that point. In contrast, the CAPSYLITE product line is designed to give a more even distribution of high level light across as broad an area as possible with no hot spots. The result is a uniform light level on the target that maximizes the impact of the halogen source.

### Thermal Performance

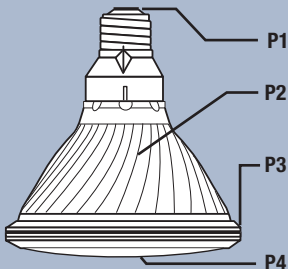

	Temperature (°C)				
	Maximum Allowed		Open Air		
	P1	P3	P2	P3	P4
40PAR20 IR	227.00	160.00	164.65	121.03	194.93
40PAR30 IR	227.00	160.00	125.89	77.45	117.33
50PAR30 IR	227.00	160.00	138.70	88.35	149.54
40PAR30LN IR	227.00	160.00	125.89	77.45	117.33
50PAR38 IR	227.00	160.00	123.66	62.65	96.62
60PAR38 IR	227.00	160.00	140.93	65.85	113.07

**United States**  
**OSRAM SYLVANIA**  
 100 Endicott Street  
 Danvers, MA 01923

**Trade**  
 Phone: 1-800-255-5042  
 Fax: 1-800-255-5043

**National Accounts**  
 Phone: 1-800-562-4671  
 Fax: 1-800-562-4674

**OEM/Special Markets**  
 Phone: 1-800-762-7191  
 Fax: 1-800-762-7192

**Display/Optic**  
 Phone: 1-888-677-2627  
 Fax: 1-800-762-7192

**Canada**  
**OSRAM SYLVANIA LTD.**  
 2001 Drew Road  
 Mississauga, ON L5S 1S4

**Trade**  
 Phone: 1-800-263-2852  
 Fax: 1-800-667-6772

**OEM/Special Markets/Display/Optic**  
 Phone: 1-800-265-2852  
 Fax: 1-800-667-6772