

LINEARlight Colormix

Rigid Colormixing LED Module

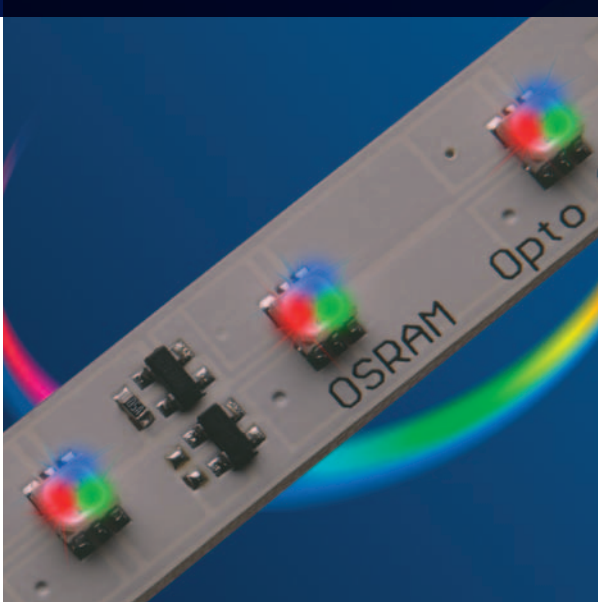

SYLVANIA LINEARlight Colormix modules provide dynamic control of colored illumination. Each individual LED contains red, green, and blue chips in one LED package. LINEARlight Colormix is optimally paired with OPTOTRONIC® 24Vdc Power Supplies and RGB 3CH DIM and OT RGB Sequencer controllers or OT RGB DMX to yield an infinite choice of colors, including white. This unique method of colormixing within each LED achieves better color consistency and uniformity than by combining separate, colored LEDs. LINEARlight Colormix modules are easily configured with available connector accessories.

These dynamic features enable the systems to be used in a wide range of large scale applications, including edge lighting of transparent and diffusing materials, illuminating facades and coves and architectural applications. These modules are ideal for wherever temperatures or space limitations prevent the use of conventional means of illumination.

Key Features & Benefits

- Each Multi LED contains an individually powered red, green and blue chip; this unique method of colormixing achieves excellent color consistency and uniformity
- Modules may be field cut to achieve a customized fit
- LEDs are closely spaced to minimize hot spots in shallow installations
- RGB dimmable by pulse width modulation, a method that maintains consistent lumen output and color
- Long life: up to 50,000 hours when temperature at Tc point is maintained at 40°C

Product Offering

Ordering Abbreviation	Wattage	Color
LNRLRMX/LM01M/RGB 1.48FT	8.3	RGB

Application Information

Applications

- Accent lighting
- Backlighting
- Controlled color sequencing
- Cove lighting
- Edge lighting

Specifications and Certifications

RoHS compliant



Specification Data

Catalog #	Type
Project	
Comments	
Prepared by	Date

Ordering Information

Item Number	Ordering Abbreviation	Module Length (ft)	No. of LEDs	Power (W)	Voltage (Vdc)	Current (Amps)	Wavelength	Watts/ft	Lumens (lm)
70080	LNRLRMX/LM01M/RGB	1.48	30						
	Red Channel			1.8	24	0.075	617nm	1.2	32
	Green Channel			3.6	24	0.15	525nm	2.4	51
	Blue Channel			2.9	24	0.12	467nm	2.0	8

Note:

All data is related to entire module measured at Tc point of 25°C. Data reflects statistical mean values. Actual data may differ depending on variances in the manufacturing process. End users need to take into account the lumen depreciation as the temperature rises with various thermal management solutions installed.

Ordering Guide

LNRLRMX	/	LM01M	/	RGB
Module Name		Style		Red, Green, Blue, Colormix
LINEARlight Colormix				

Power Supply Information

Application	OPTOTRONIC® Power Supply	Ordering Code	Qty.	OPTOTRONIC RGB Control Interface	Ordering Code	Qty.	Max. length of LINEARlight Colormix Strip	No. of Modules	Controllers
Colormixing, Color Changing, Sequencing	OT20/120-240/24S	51512	1	OT RGB 3CH DIM	51517	1	2.9 ft.	2	*Three 0-10V controllers or 100 K ohm potentiometers required ** DMX controller
	OT50/120/24LP	51598	1	OT RGB Sequencer	51518		8.9 ft.	6	
	OT75/120-277/24E	51514	1	OT DMX RGB	51600		13.3 ft.	9	
	OT96/120-277/24D	51510	1				14.8 ft.	10	
	OT96/120-277/24	51511	1				14.8 ft.	10	
	OT240/120-240/24/CH3	51515	1				3 x 13.3 ft.	3 x 9	

*Please contact SYLVANIA for a list of approved 0-10V controllers.

** DMX controller is only compatible with OT DMX RGB.

Notes:

1. A maximum of 5 modules can be connected in a single run. Please reference the "Wiring Diagram" in this document for specifics.
2. This table is for indoor applications. For outdoor applications reduce the number of modules by one.
3. OPTOTRONIC power supplies are optimally paired with SYLVANIA LED modules and are specifically designed with protection features for safe operation.

Minimum and Maximum Ratings

Parameter	Symbol	Values
Operating Temperature at Tc point	T_{op}	-30 to +75°C (-22 to +162°F)
Storage Temperature Range	T_{stg}	-30 to +80°C (-22 to +176°F)
Voltage Range	V_{max}	23 – 25Vdc
Reverse Voltage	V_R	25Vdc

Notes:

1. Exceeding maximum ratings may damage the LED module and pose potential safety hazards.
2. Elevated operating temperatures can be expected to negatively impact the service life in terms of lumen output.
3. Incorrect wiring may damage the LED module.
4. Not intended for use with constant current power supplies.

Accessories

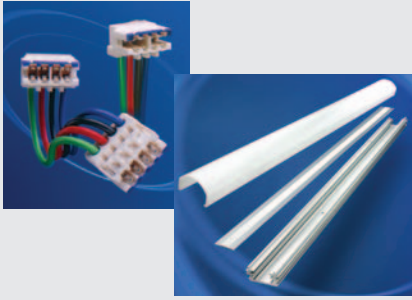

Item Number	Ordering Abbreviation	Length (in)
70114	CLRMXCONN/LM4PINFeeder	0.29
70110	CLRMXCONN/LMConn45	2.3
71236	LINEARlight Track 1.6P	18.0
71237	LINEARlight Track 4.6P	56.0
71238	LINEARlight Track 1.6D	18.0
71239	LINEARlight Track 4.6D	56.0

Assembly Diagram

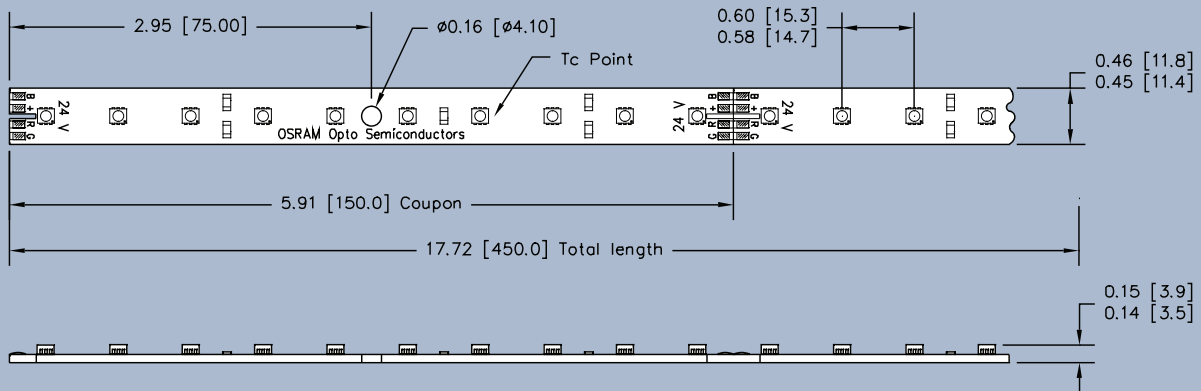

Wiring Diagram

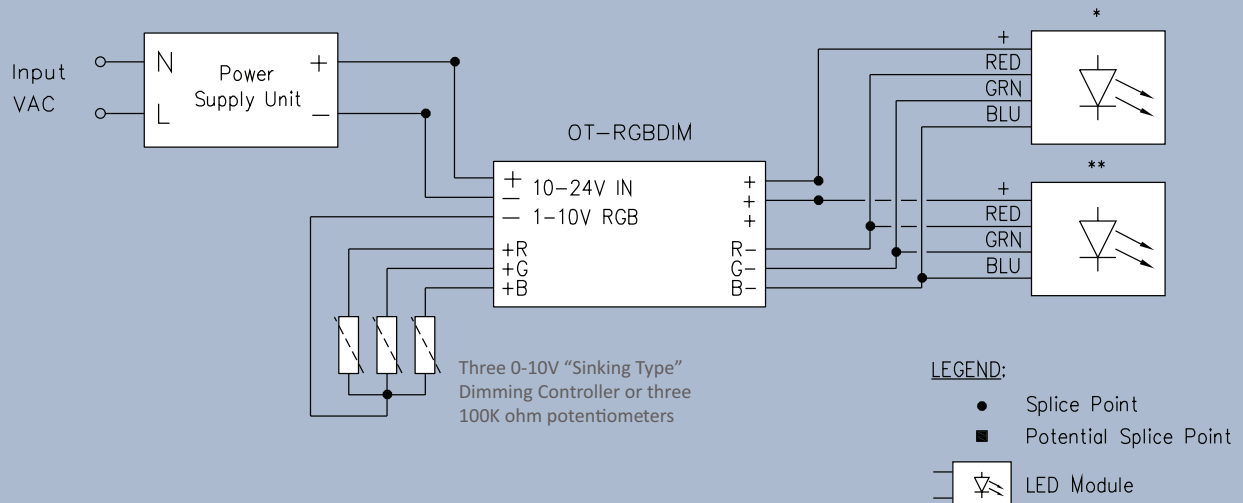

Reference the "Power Supply Information" for the maximum product load per power supply.

Circuit Requirements:

* Maximum 5 modules per single power feed.

** Remaining load to be connected with additional power feeds.

Safety Information

WARNING: ONLY QUALIFIED PERSONNEL SHOULD PERFORM INSTALLATION.

TO AVOID ELECTRICAL SHOCK OR COMPONENT DAMAGE, DISCONNECT POWER BEFORE ATTEMPTING INSTALLATION OF THE POWER SUPPLIES AND/OR MODULES.

Failure to install the power supplies and/or LED modules in accordance with the National Electric Code (NEC), all applicable Federal, State and local electric codes as well as the specific Underwriters Laboratories (UL) safety standards for the installation, location and application may cause serious personal injury, death, property damage and/or product malfunction.

1. The LED module itself and all its components shall not be subjected to mechanical stress and assembly must not damage or destroy conducting paths on the circuit board.
2. Installation of LED modules shall be made with regard to all applicable electrical and safety standards. Only qualified personnel should be allowed to perform installations.
3. Observe correct electrical polarity, incorrect polarity may destroy the module.
4. Electrostatic Discharge (ESD) precautions shall be incorporated when handling or installing the module.
5. Damage by corrosion and improper heat sinking will not be honored as a materials defect claim. It is the user's responsibility to ensure adequate heat sink and protection against corrosive agents such as moisture, condensation and other harmful elements.
6. Modules may be hot to the touch. Use caution when handling.

Assembly Information

1. The module should be installed on flat surfaces to facilitate intimate contact between the circuit board and the substrate material. The module should not be installed on curved surfaces.
2. Mount the module using the predrilled mounting holes.
3. Heat Sink compounds may be used to facilitate heat transfer from the module to the heat sink material.
4. Ensure the power supply has adequate power to operate the load. See the requirements under the section titled Power Supply Ordering Information.
5. Make electrical connection from the power supply to the LED modules using the LINEARlight Colormix – Connector System.
6. A maximum of five LINEARlight Colormix LED modules can be operated from a single power feed. Operation of greater than five LED modules in series will exceed the current capacity of the connector system.

Application Information (continued)

Application Notes

1. Installation of the LINEARlight Colormix must provide for thermal management to avoid premature failure of the product and to obtain expected service life. Service life (i.e. lumen depreciation) is primarily a function of LED temperature which is to be monitored on the circuit board at the designated Tc point temperature of 40°C and should be sufficient to enable a service life of 50,000 hours.
2. There is no exact installation prescription for obtaining an appropriate Tc point temperature, due to variations in fixture designs. In general, the LINEARlight Colormix module should be adhered to a flat, metal surface which has enough surface area to transfer the heat from the LED to the surrounding air. The metal surface can be part of the mass of the fixture itself.
3. Concerning fixture design, it is important to understand that once heat is transferred to a "heat sink", that heat must still be allowed to escape the "system". A heat sink transferring the thermal energy to the inside of an enclosed cavity may ultimately be of little use.
4. The fixture manufacturer's strategy should be to design a prototype fixture and test that fixture in an appropriate environment while monitoring the temperature at the Tc point, which should be allowed enough time to reach thermal equilibrium. Tc point temperature can be measured with a standard thermocouple in direct contact with the circuit board at the Tc point or with ML4C Series non-reversible OMEGALABELS (www.omega.com) or equivalent.

SYLVANIA is a registered trademark of OSRAM SYLVANIA Inc.
SEE THE WORLD IN A NEW LIGHT is a registered trademark of OSRAM SYLVANIA Inc.
OPTOTRONIC is a registered trademark of OSRAM GmbH.
Specifications subject to change without notice.

United States
OSRAM SYLVANIA
100 Endicott Street
Danvers, MA 01923

Trade
Phone: 1-800-255-5042
Fax: 1-800-255-5043

National Accounts
Phone: 1-800-562-4671
Fax: 1-800-562-4674

OEM/Special Markets
Phone: 1-800-762-7191
Fax: 1-800-762-7192

Display/Optic
Phone: 1-888-677-2627
Fax: 1-800-762-7192

Canada
OSRAM SYLVANIA LTD.
2001 Drew Road
Mississauga, ON L5S 1S4

Trade
Phone: 1-800-263-2852
Fax: 1-800-667-6772

OEM/Special Markets/Display/Optic
Phone: 1-800-265-2852
Fax: 1-800-667-6772

www.sylvania.com